

1.25Gbps Multimode GBIC Transceiver (500m) ATR-G0001



■ Features

- a. Compliant with IEEE802.3z 1000Base-sx Gigabit Ethernet
- b. Single 3.3V to 5V Power Supply
- c. PECL Signal
- d. Hot-pluggable Capability
- e. Duplex SC Connector



■ Applications

- a. Ethernet
- b. Fiber Channel
- c. Fast Ethernet

■ Absolute Maximum Ratings

Parameter	Symbol	Min.	Max.	Unit
Supply Voltage	V _{CC}	0	+6	V
Storage Temperature	T _S	-40	+85	°C
Voltage at any Input Pin	V _{IN}	-0.5	V _{CC}	V

■ Recommended Operating Conditions

Parameter	Symbol	Min.	Typ.	Max.	Unit
Supply Voltage	V _{CC}	+3.1	-	+5.5	V
Operating Temperature	T _{OP}	0	-	+70	°C
Data Rate	Gigabit Ethernet	-	1.25	-	Gbps
	Fiber Channel	-	1.0625	-	Gbps

■ Transmitter

Parameter	Symbol	Min.	Typ.	Max.	Unit
Center Wavelength	λ_c	830	850	860	nm
Spectral Bandwidth(RMS)	$\Delta\lambda$	-	-	0.85	nm
Output Power	P _O	-9.5	-	-4	dBm
Optical Extinction Ratio	ER	9	-	-	dB
Rise/Fall Time (20%~80%)	t _r /t _f	-	-	260	ps
Total Jitter	TJ	-	-	227	ps
Output Eye Diagram	IEEE 802.3z compliant				

1.25Gbps Multimode GBIC Transceiver (500m) ATR-G0001



Receiver

Parameter	Symbol	Min.	Typ.	Max.	Unit
Wavelength Range	λ	770	-	860	nm
MIN. Input Power (Sensitivity) @1.25Gbps BER= 10^{-12}	P_{MIN}	-	-	-17	dBm
MAX. Input Power (Saturation)	P_{MAX}	-3	0	-	dBm
Optical Return Loss	ORL	12	-	-	dB
Signal Detect-Asserted	P_A	-	-	-18	dBm
Signal Detect-Deasserted	P_D	-30	-	-	dBm
Signal Detect Hysteresis	-	0.5	-	5	dB

Pin Assignment

PIN#	PIN NAME	SEQUENCE	PIN#	PIN NAME	SEQUENCE
1	RS_LOS	2	11	RGND	1
2	RGND	2	12	-RX_DAT	1
3	RGND	2	13	+RX_DAT	1
4	MOD_DEF(0)	2	14	RGND	1
5	MOD_DEF(1)	2	15	V _{CCR}	2
6	MOD_DEF(2)	2	16	V _{CCT}	2
7	TX_DISABLE	2	17	TGND	1
8	TGND	2	18	+TX_DAT	1
9	TGND	2	19	-TX_DAT	1
10	TX_FAULT	2	20	TGND	1

Mechanical Dimension (mm)

SC Connector

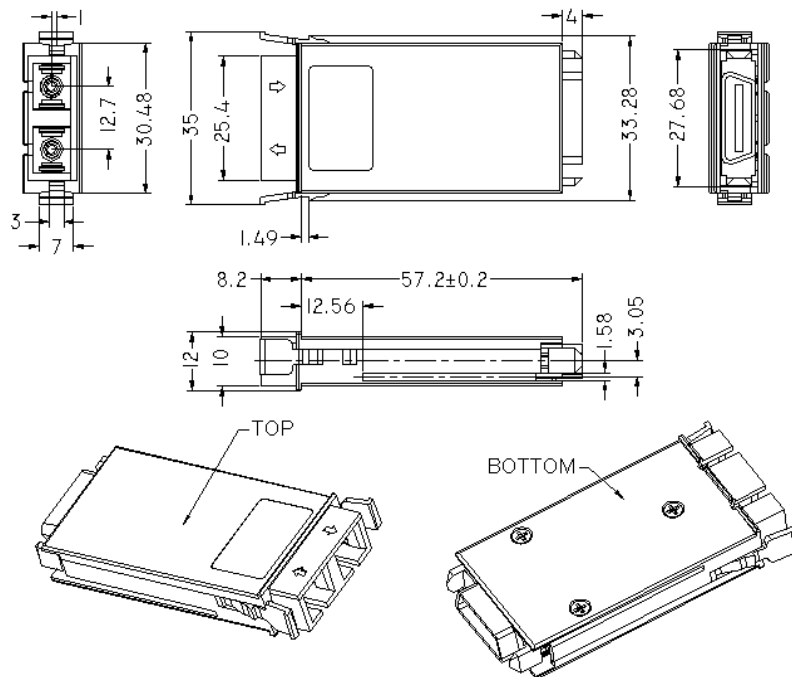

1.25Gbps Multimode GBIC Transceiver (500m) ATR-G0001



Application Circuit Diagram(AC-AC)

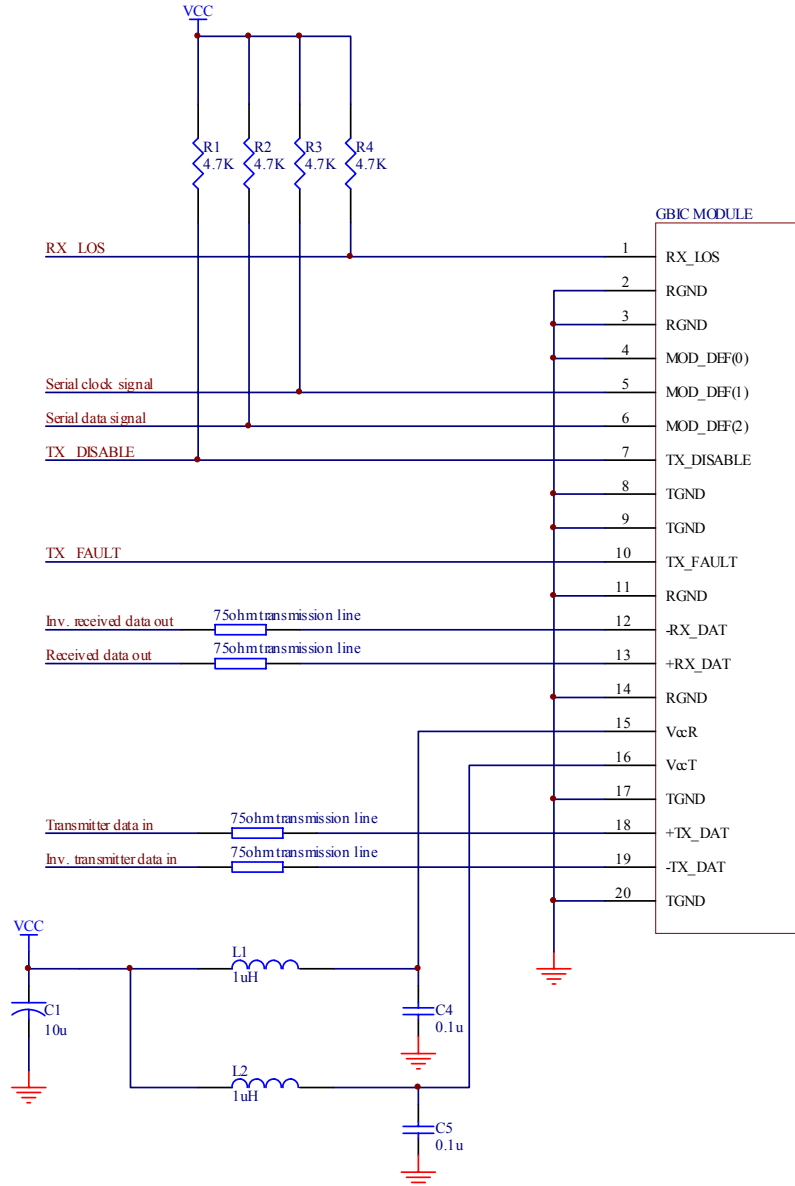

Ordering Information

Part No.	Laser	TX Power (dBm)	RX Sens (Max.) (dBm)	Supply Voltage	Distance
ATR-G0001	VCSEL/PIN-TIA	-9.5 to -4	-17	3.3/5V	500m